

Safety Rules



This is the safety alert symbol. It is used to alert you to potential personal injury hazards. Obey all safety messages that follow this symbol to avoid possible injury or death.

Read and understand all safety rules and operating instructions before using this tractor attachment.

Follow all safety rules and operating instructions provided by your tractor's manufacturer when using attachment.

Never allow children or untrained persons to operate tractor or attachment.

Reduce tractor speed to slowest setting when towing or operating on slopes.

Operate up and down slopes, never across the face of slopes.

Do not carry passengers on tractor or attachment.

Avoid sudden turns or maneuvers.

Do not tow attachment on public roadways.

Do not remove warning decals from product.

Check product for worn, loose, or damaged parts before each use. If any damage is present, repair the product before using.

Check product for loose or missing fasteners before each use. Tighten or replace fasteners as needed before using.

Do not exceed tractor speed of 3 miles per hour when operating or towing Lawn Aerator.

Lawn Aerator has sharp points; always ***HANDLE WITH CARE.***

Always wear proper footwear and hand protection when operating or handling the Lawn Aerator.

Carton Contents

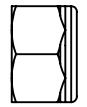
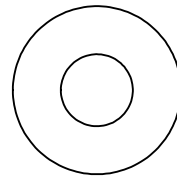
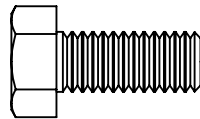
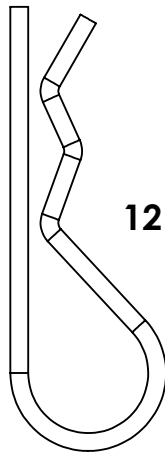
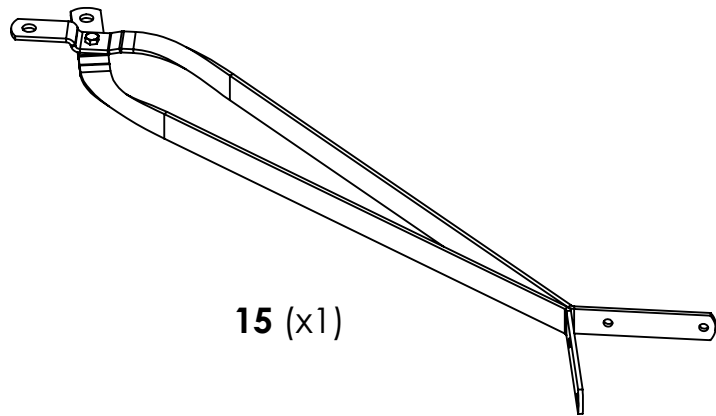
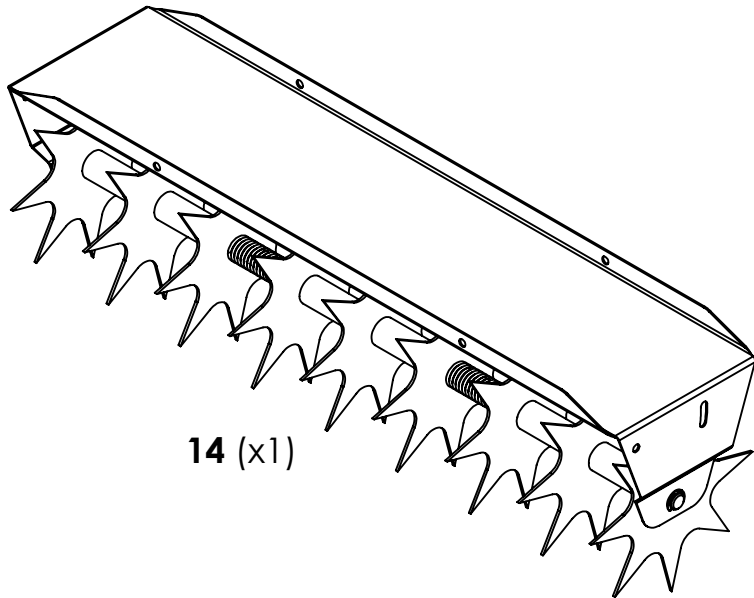
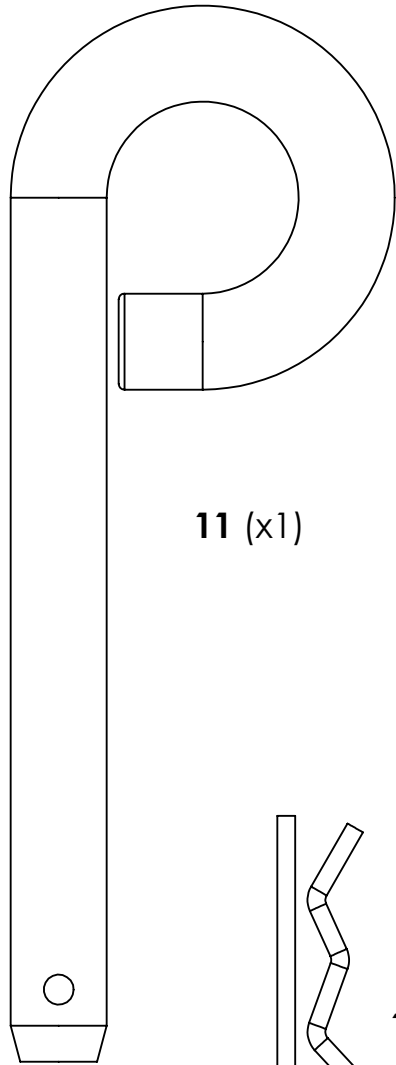

TOOLS REQUIRED FOR ASSEMBLY:

- 1/2" Wrench and Socket

Assembly Instructions

- 1** Unfold drawbar as shown.

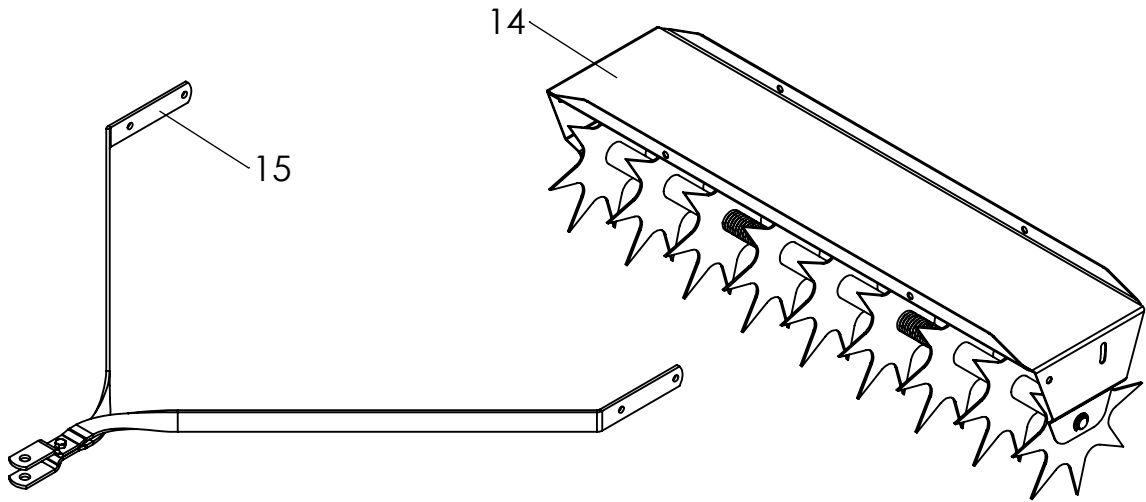

- 2** Attach drawbar to body and tighten hardware as shown.

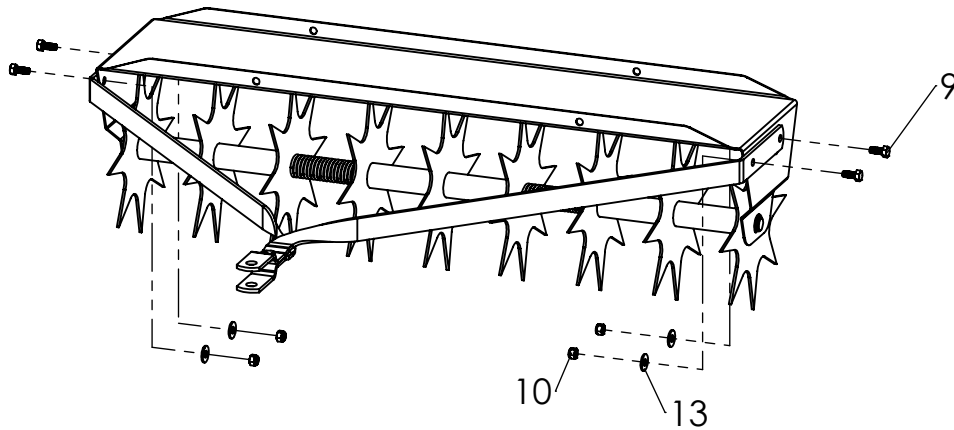

- 3** Install hitch pin (11) and secure to vehicle with supplied cotter pin (12) as shown.

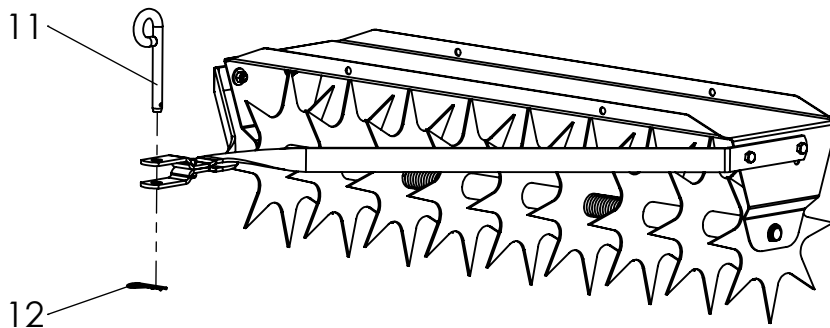

Operating Instructions

Before Using Lawn Aerator:

1. Read all Safety Rules found on page 2.

How to Aerate Lawn:

1. Mow lawn and remove loose clippings. Grass should be less than 3" tall.
2. If ground is extremely hard or dry, it should be watered for one to two hours before aerating.
3. Do not aerate if ground is too wet or muddy.
4. Attach Lawn Aerator to tractor using supplied hitch pin.
5. Loosen all four bolts on the drawbar and rotate tray so it is level to the ground, retighten all hardware before resuming work.
6. Engage tractor drive at its slowest speed and begin aerating. Increase tractor speed as desired.
7. Aerate in straight lines whenever possible and avoid sharp turns.
8. Optimal aeration will yield a spike depth of roughly 2-3 inches. Add weight and/or reduce tractor speed as necessary to improve aeration.
9. Up to two standard concrete blocks (80 lbs), or other weights, can be added to the top plate to increase aeration depth. Always secure weights to top plate using bungee straps (not provided).

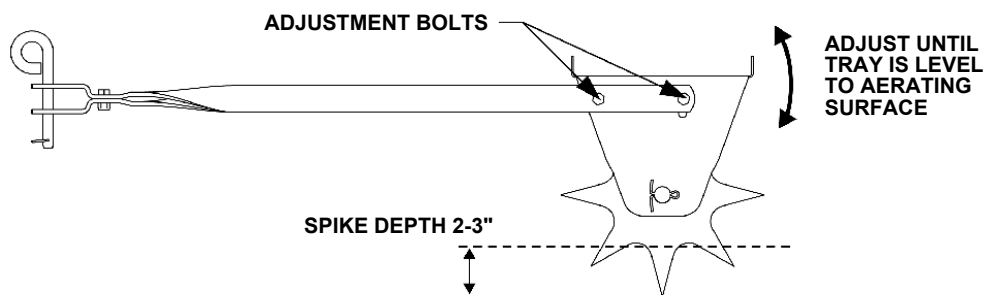

Periodic Maintenance:

- Tighten fasteners as needed before each use
- Keep aerator clean and dry to prevent rust
- Inspect for any damaged or loose hardware, replace as needed

Warranty

If this product fails due to a defect in material or workmanship within TWO YEARS from the date of purchase, we will at our option repair or replace it free of charge. This warranty excludes springs and tines, which are expendable and become worn during normal use.

This warranty does not cover:

- Repairs necessary because of operator abuse or negligence.
- Equipment used for commercial or rental purposes.
- Paint that is worn or faded due to normal use or exposure.

To arrange for product repair call 1-800-652-2321, or return this product to place of purchase for replacement.

This warranty gives you specific legal rights, and you may also have other rights which may vary from state to state. This warranty applies only while this product is in use in the United States.

In the space below record the purchase date of your Lawn Aerator.

Model Number **AF-36SA** _____

Purchase Date _____

Keep this Owner's Manual and your receipt in a safe place for future reference.

After the two year warranty period all replacement parts may be ordered by calling **1-800-652-2321**.

When ordering replacement parts, always give the following information:

- Product **36" SPIKE AERATOR** _____
- Model Number **AF-36SA** _____
- Part Number _____
- Part Description _____

Repair Parts

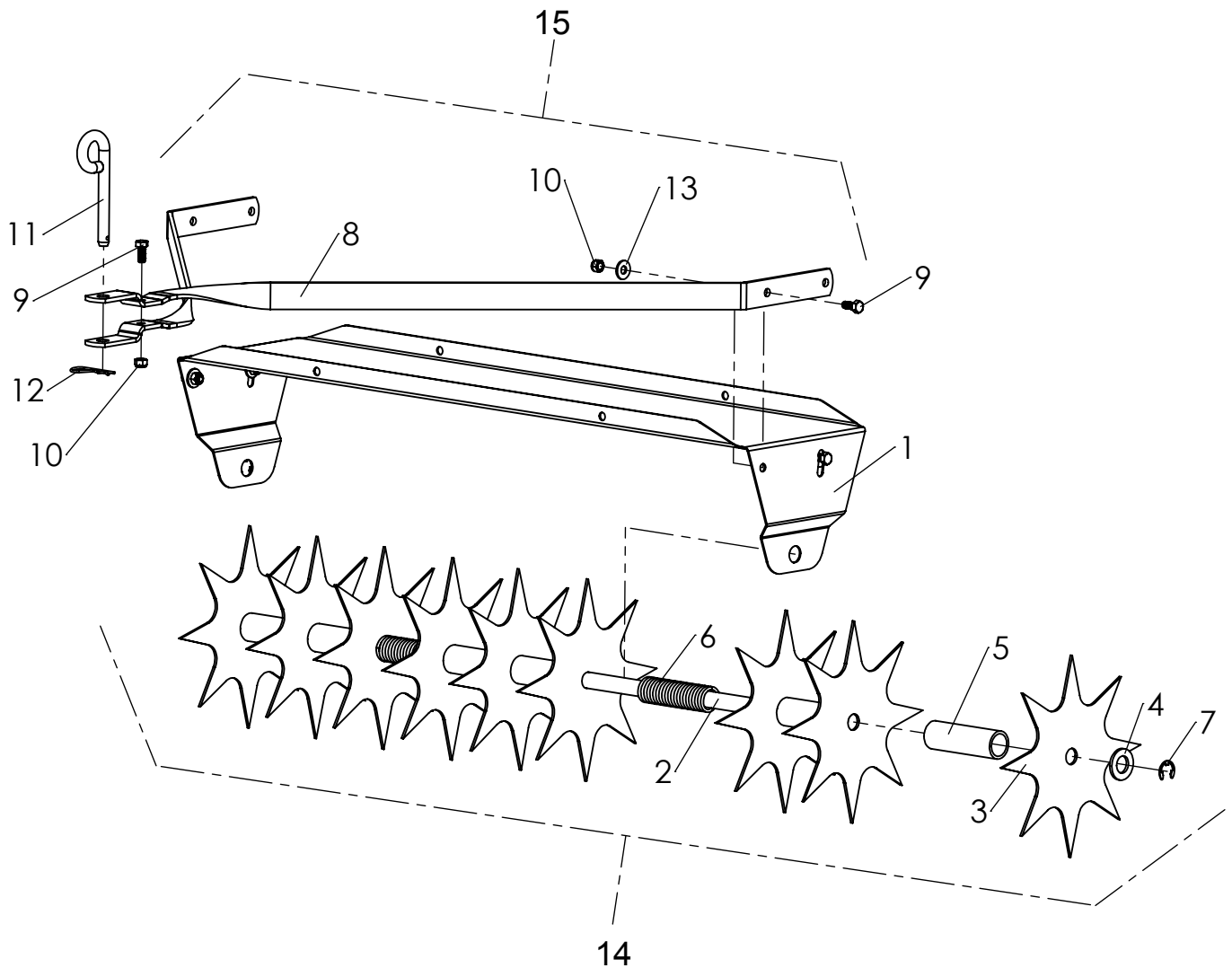

ITEM	PART NO	DESCRIPTION	QTY
1	6000619	TRAY, FORMED	1
2	6000621	AXLE, 3/4" X 35.500"	1
3	6000628	SPIKE DISC, 9.5"	9
4	3000721	WASHER, 3/4" SAE	2
5	6000626	SPACER, 1" X 4.125"	6
6	6000627	SPRING, COMPRESSION	2
7	6000773	RETAINING RING, 3/4" EXT	2
8	6000618	DRAWBAR, TWISTED	2
9	6000440	HEX HEAD BOLT, 5/16"-18 X 3/4"	5
10	3000616	HEX NUT, 5/16-18 NYLOC	5
11	6000533	PIN, HITCH	1
12	300084	HAIRPIN COTTER, 0.093" X 2-5/16"	1
13	3000711	WASHER, 5/16" USS	4
14	6000624	TRAY ASSEMBLY (incl. 1-8)	1
15	6000625-G	DRAWBAR ASSEMBLY (incl. 8-11)	1

OHIO *STEEL*
INDUSTRIES

DESIGNED AND TESTED IN
COLUMBUS, OHIO

MANUFACTURED IN VIETNAM



MODEL # AF-36SA

(800) 652-2321